



SINGLE END TRIMMERS OPTIMAX TRIM SAWS



Model OM-2

BENEFITS

- Fast, Efficient Trim Saw to Reclaim Lumber
- Keeps Operator at a Safe Distance with Unique Design & Blade Guard
- 3 Strand Chain Feed Conveyor with Adjustable Feed Speed Control
- Four Adjustable Board Length Stops for Easy Board Placement

**Frame Provides
Incline**



Model OM-3

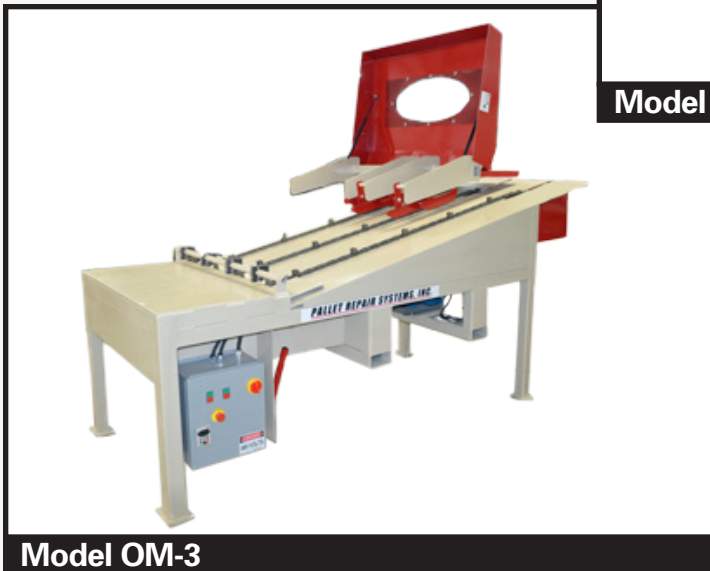

Model OM-3

OPTIMAX single end trim saws are the ultimate in fast, safe, and efficient recovery of deck boards and stringers. At up to 3,000 boards per hour an OPTIMAX saw can keep up with the highest of production demands that far exceed conventional saws. Precision infeed chains provide accurate cuts every time. The unique design of these saws also provides optimization of each and every board.



PRSGROUP INC.
2 Eastgate Drive Jacksonville, IL 62650

www.prsgroupinc.com
217-291-0009



SINGLE END TRIMMERS OPTIMAX TRIM SAWS

| SPECIFICATIONS | | |
|-------------------------|---------------------------|---------------------------|
| | OM-2 | OM-3 |
| Motors | 7.5 HP (5.592 KW) | 7.5 HP (5.592 KW) |
| Blades | 12" – 14" (0.30 – 0.35 m) | 12" – 14" (0.30 – 0.35 m) |
| Feed Motor | 1 HP (0.7459 KW) | 1 HP (0.7459 KW) |
| Maximum Lumber Capacity | 2" | 2" |
| Output Capacity | 18" – 58" (0.45 – 1.47 m) | 18" – 58" (0.50 – 1.47m) |
| Boards / Hour | 2,800 max | 2,800 + |

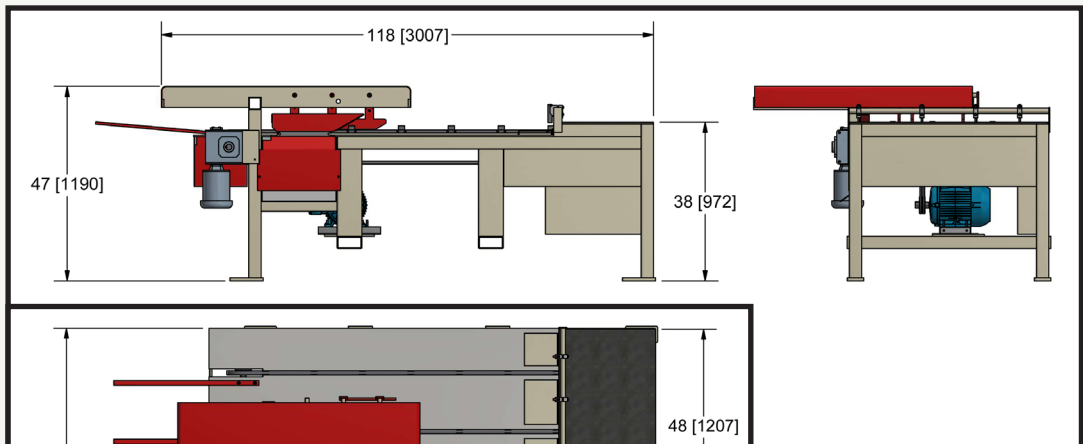

Model OM-2 View of Motor

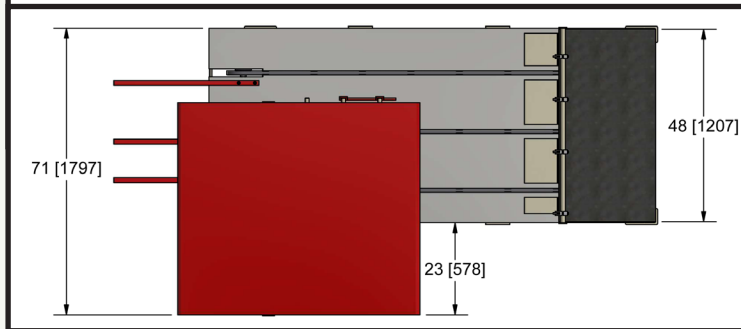

Model OM-2 Top View

Model OM-3 Top View

Model OM-3 View of Motor

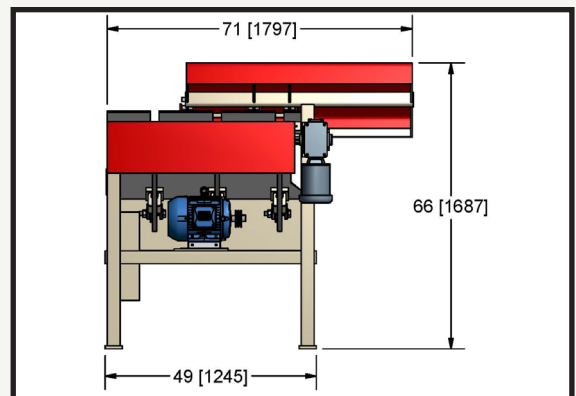
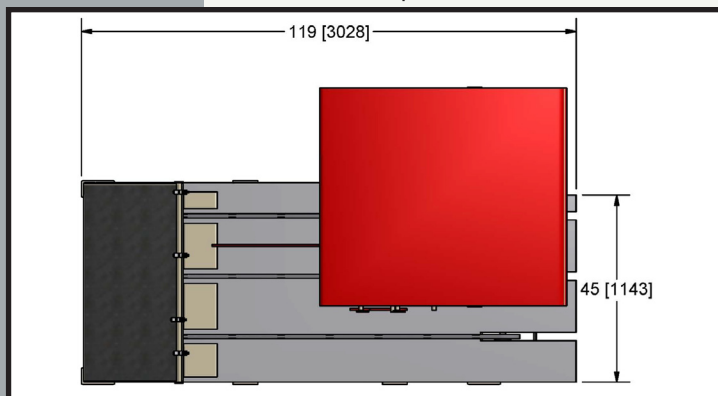

PRSGROUP INC.
2 Eastgate Drive Jacksonville, IL 62650

www.prsgroupinc.com
217-291-0009